



COMPANY PROFILE



WELCOME TO JEREMIAS GROUP

The Jeremias Group, headquartered in Wassertrüdingen (Bavaria), is one of the world's leading manufacturers of flue systems and chimney systems in all areas of heat and power generation for industrial and residential applications.

Strong, open and international – that's how we have been presenting ourselves for almost 50 years. Worldwide production sites and sales offices represent entrepreneurial success, ambitious visions and healthy growth. With innovative products, outstanding service and highly qualified employees, we want to inspire our customers every day and achieve the goal of sustainable joint success.

Currently, our product range includes more than 100 different CE-certified systems for private and commercial applications as well as free-standing steel chimneys with a diameter of up to four meters.



STRONG, OPEN AND INTERNATIONAL



6
PRODUCTION
SITES



83.000+
REFERENCES
WORLDWIDE



1.400+
EMPLOYEES



60+
COUNTRIES

FROM A FAMILY BUSINESS TO A GLOBAL PLAYER

The Jeremias group dates back to the early 70's with the discovery of a niche sector in relining chimney systems due to the use of new technologies in the heating sector.

Chimney sweeper Walter Engelhardt together with his partner Johann Melzner founded a company dedicated to chimney relining.

Following the footsteps of his father, Stefan Engelhardt started with the industrial manufacturing of stainless steel flue and chimney systems and founded Jeremias GmbH in 1984.

This led to a fast and healthy growth of the company with subsequent opening of subsidiaries and addition of sales partnerships across the globe. Still family-owned, Jeremias today is one of the world leaders in manufacturing of chimneys and flue systems and is actively working to strengthen its position as the most customer-orientated company in the market with innovative and high quality product solutions.

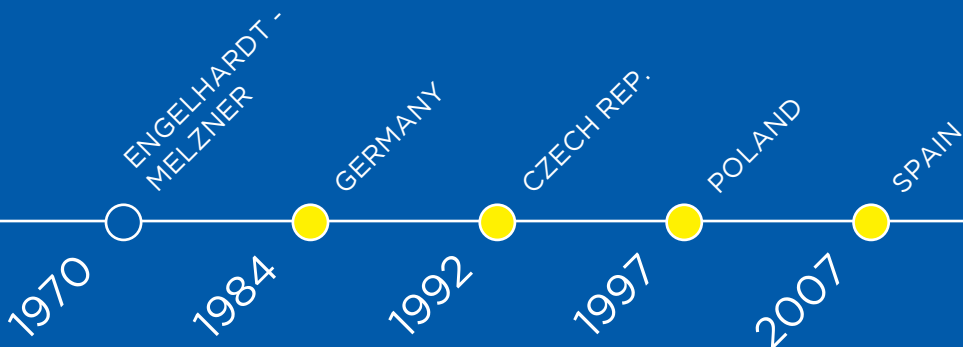

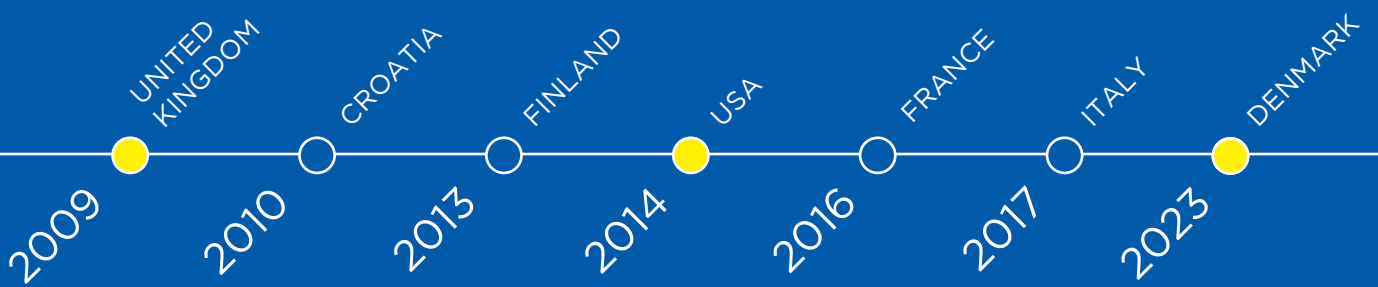

GLOBAL PRESENCE AND PROXIMITY TO CUSTOMER

Since its inception, the philosophy of the Jeremias Group has been characterized by a gradual, consistent and strong spirit of expansion. With eight production facilities worldwide, six subsidiaries and numerous sales partners nationally and internationally, we can guarantee our customers optimal service as well as permanent and location-independent accessibility.

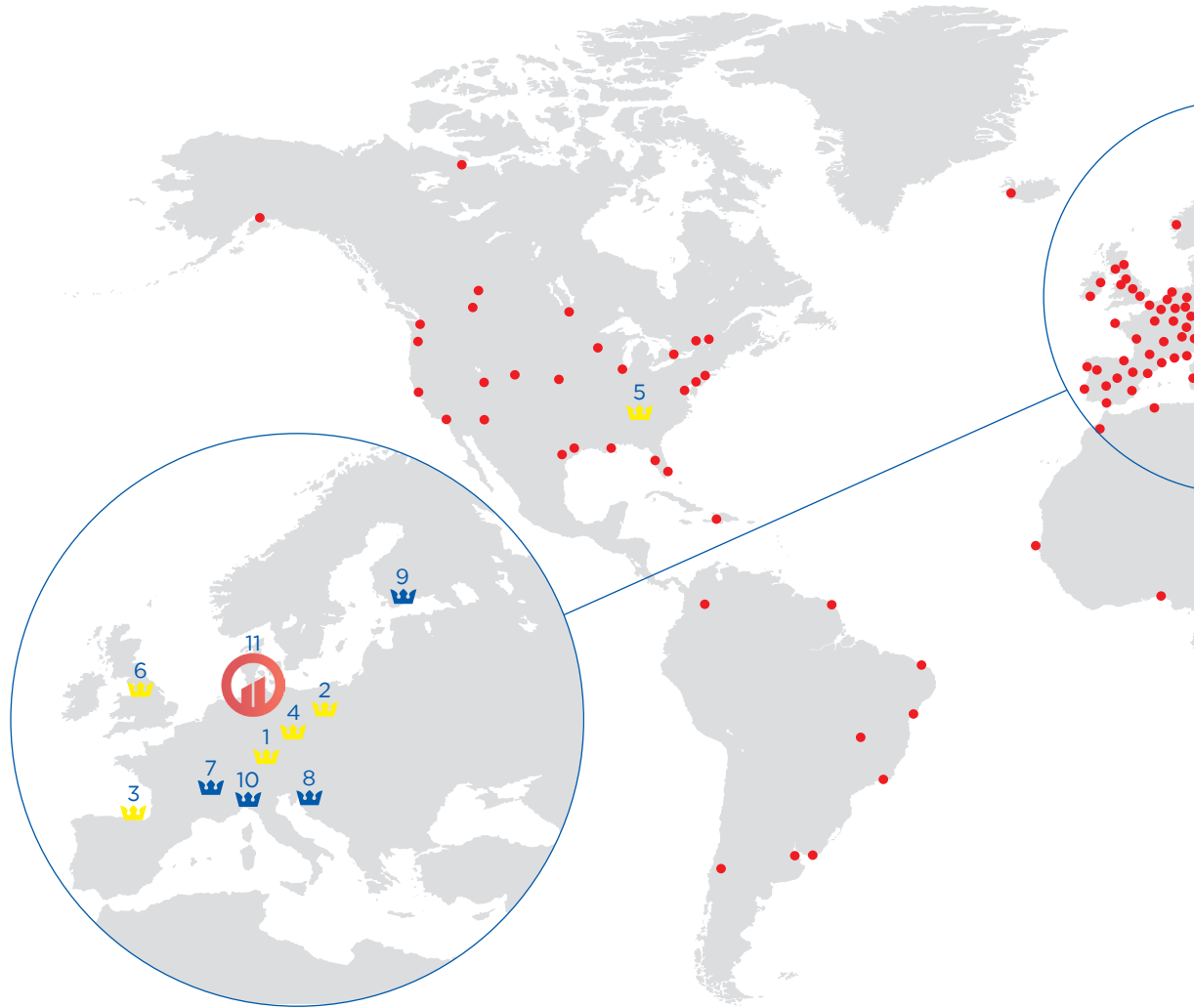

1. GERMANY
www.jeremias.de

2. POLAND
www.jeremias.pl

5. USA
www.jeremiasinc.com





6. UNITED KINGDOM
www.jeremias.uk

9. FINLAND
www.jeremias.fi

10. ITALY
www.jeremias.it



Thousands of projects realized worldwide gives a clear message: we are always and everywhere there for you!

-   PRODUCTION SITES
-  SALES OFFICES
-  REALIZED PROJECTS



3. SPAIN
www.jeremias.com.es

4. CZECH REPUBLIC
www.jeremias.cz

7. FRANCE
www.jeremias.fr

8. CROATIA
www.jeremias.hr

11. DÄNEMARK
www.avantea-global.com

A COMPLETE PRODUCT RANGE – ONE-STOP-SHOP

SINGLE WALL SYSTEMS
(RELINING)



DOUBLE WALL SYSTEMS

COLLECTIVE SYSTEMS

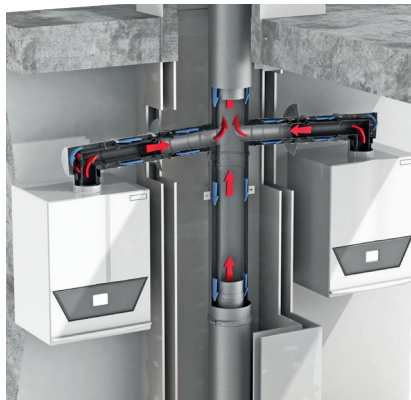

CONCENTRIC SYSTEMS FOR
GAS FIREPLACES

LIGHTWEIGHT SHAFTS

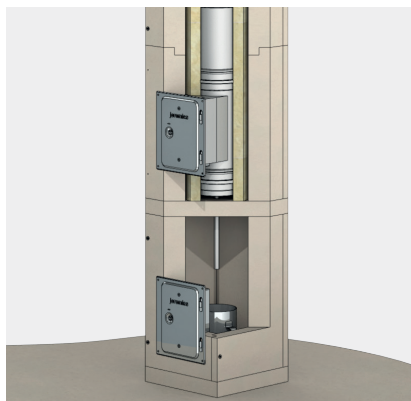

FIRE PROTECTION DUCTS

As a technology leader and catalyst in exhaust technology, we develop innovative systems for a wide variety of applications and markets. We offer our customers the widest variety of products in the market and a complete range from easy-to-install modular systems to freestanding steel chimneys.



CONCENTRIC SYSTEMS

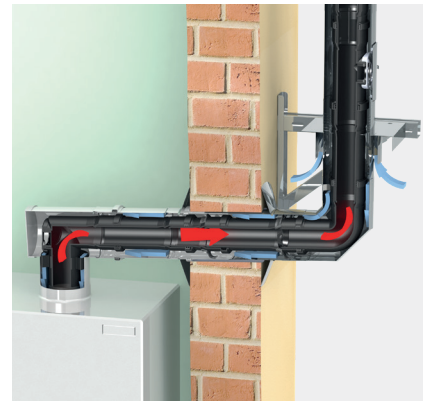

STOVE PIPES

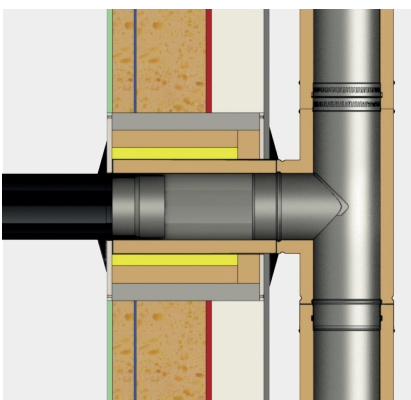

SAUNA CHIMNEYS



A COMPLETE PRODUCT RANGE – ONE-STOP-SHOP

SILENCERS



TERMINALS

LAUNDRY SHAFTS



DAMPERS

VENTILATION SYSTEMS



VENTILATION TOWERS

At Jeremias, you get much more than just flue systems. In our wide product range you will find individual solutions for sound attenuation, fire protection, ventilation and laundry discharge systems, as well as a comprehensive range of accessories that completes our product portfolio.

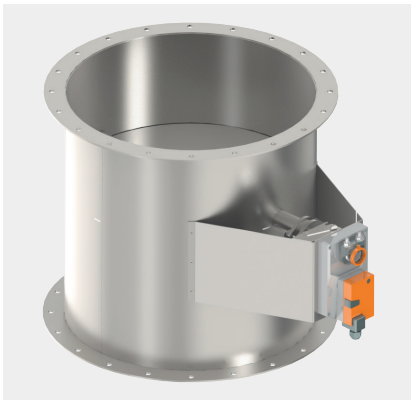
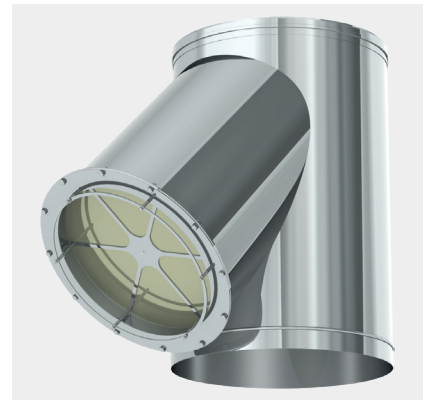

CHIMNEY HOODS

IMPLOSION / EXPLOSION
RELIEF VALVES

FREESTANDING CHIMNEYS



SUITABLE SOLUTIONS FOR A WIDE RANGE OF APPLICATION AREAS



DOMESTIC AND RESIDENTIAL SOLUTIONS



CHIMNEY RELINING



CONDENSING BOILERS

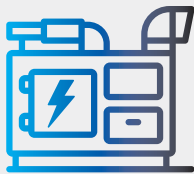

COMMERCIAL SOLUTIONS



KITCHEN EXHAUST

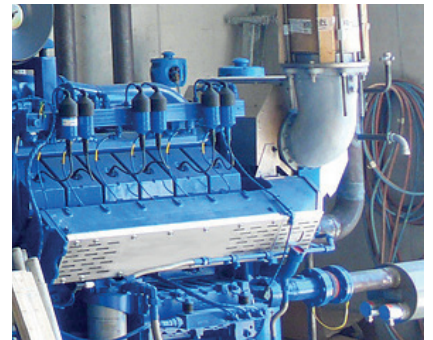

CHPS

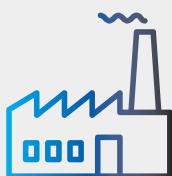

INDUSTRIAL SOLUTIONS

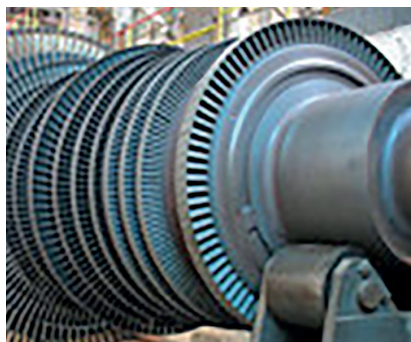

GASTURBINES



(STEAM-) BOILERS

As one of the world's leading manufacturers, Jeremias offers flue, chimney and ventilation systems for a wide range of applications in domestic, commercial and industrial sectors. No matter what purpose it is: Jeremias has the right solution



STOVES AND FIREPLACES



GAS FIREPLACES

- BIOMASS BOILERS
- HEAT-RECOVERY VENTILATION



CONDENSING BOILERS



GENERATORS

- GAS-, OIL- UND BIOMASS BOILERS
- VENTILATION
- COFFEE ROASTERS
- PIZZA OVENS
- BAKERIES



MARITIME APPLICATIONS



ENGINE TEST STANDS

- EMERGENCY BACKUP GENERATORS
- INDUSTRIAL VENTILATION
- INDUSTRIAL KITCHEN EXHAUST

WE REALIZE PROJECTS FOR DIFFERENT INDUSTRIES

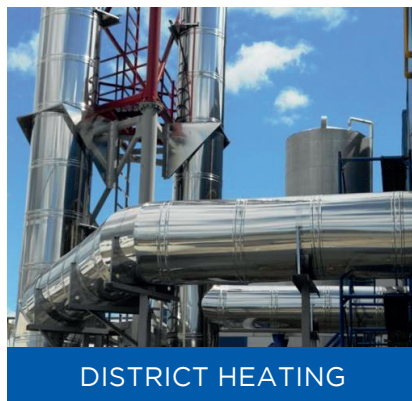
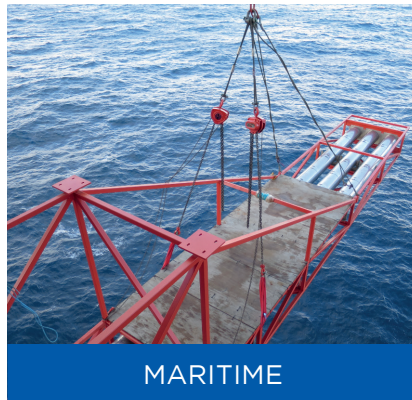



In the last 40 years Jeremias has carried out tens of thousands of projects worldwide. We offer individual solutions for all applications and all energy sources with efficient flue systems. Whether production plants, power plants, clinics, hotels, football stadiums or public facilities, in new buildings or modernization: Jeremias flue systems are used in every sector!





SHOPPING CENTERS



HOTELS



COFFEE ROASTERIES



PAPER INDUSTRY



UNIVERSITIES



FOOD INDUSTRY



INCINERATORS



INDUSTRIAL KITCHENS



INDUSTRIAL VENTILATION



FAMILY HOMES



PIZZA OVENS



OIL PLATFORMS

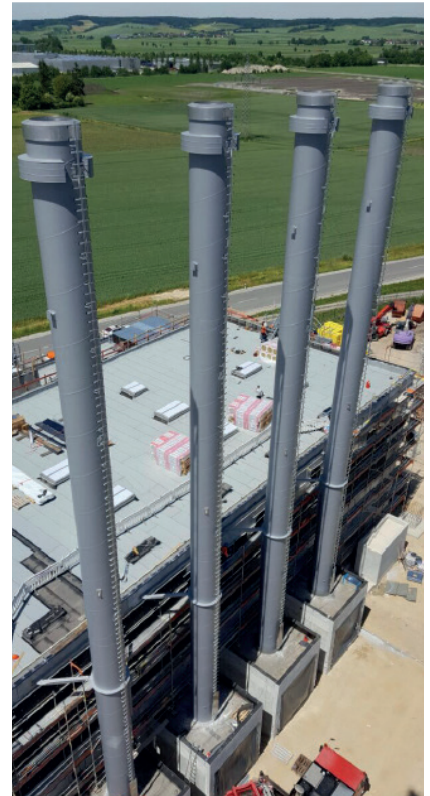

AUTOMOTIVE INDUSTRY



INDUSTRIAL BAKERIES



STADIUMS



FAMILY HOMES



HEATING UNITS



GEOHERMAL INDUSTRY

- BREWERIES
- RAILWAY STATIONS
- PUBLIC BUILDINGS
- PORTS
- CRUISE SHIPS
- AIRPORTS
- EXHIBITION CENTERS
- MUSEUMS

- CONFERENCE CENTERS
- SCHOOLS
- THEATERS
- SWIMMING POOLS

...AND MUCH MORE:
[www.jeremias-group.com/
references](http://www.jeremias-group.com/references)

EXPECT ONLY THE BEST FROM US!

MORE QUALITY

The top quality of Jeremias products is based on the deep-seated quality awareness of our employees. As an ISO9001-certified company, we maintain a quality management system for the continuous optimization of products, processes and activities. Our own test facilities as well as externally monitored production controls ensure a consistent high quality. In addition to mandatory standards and certifications, Jeremias flue systems also meet national and application specific norms.

MORE SERVICE

We are partners of our customers and we want to inspire them every day with our outstanding service. We continue to develop in partnership with our customers and set the highest standards in the industry with expert advice, unique flexibility and a passion to meet even the most complex individual demands.

MORE INNOVATION

As a technology leader, we always strive for innovative product range additions and further expand our range of systems to meet the needs of our customers. In cooperation with the manufacturers of heat generators and fireplaces, we are developing new systems and product solutions according to market trends for new application areas.



A FAIR AND RELIABLE PARTNER

OUR CUSTOMERS

The basis of our many years of success is the company's philosophy based on tradition and values. Proximity to customer always comes first for us. Our customers can rely on our professional support, many years of experience and expert advice. As a family-owned company, we are down-to-earth and reliable partner. The relationships with our business partners are usually decades long and are characterized by constructive and fair cooperation.

OUR EMPLOYEES

The extraordinary achievements of our employees are one of the main success factor for Jeremias. We don't consider our work as a routine rather we consider our work to be special and want to offer an optimal solution to our customers with competence and personal commitment. In doing so, we rely on open and trust worthy communication in flat hierarchies. We offer excellent development opportunities to our employees leading to form a powerful team.



GERMANY

Jeremias Abgastechnik GmbH
Opfenrieder Str. 12
D-91717 Wassertrüdingen
Phone: +49 9832 6868-50
Mail: welcome@jeremias-group.com
www.jeremias-group.com

POLAND

www.jeremias.pl

USA

www.jeremiasinc.com

SPAIN

www.jeremias.es

CROATIA

www.jeremias.hr

ITALY

www.jeremias.it

CZECH REPUBLIC

www.jeremias.cz

FINLAND

www.jeremias.fi

FRANCE

www.jeremias.fr

UNITED KINGDOM

www.jeremias.uk

JEREMIAS IS REPRESENTED IN THE FOLLOWING COUNTRIES:

Austria | Switzerland | Belarus | Belgium | Brazil | Bulgaria | China (Hongkong) | Denmark | Estonia | Greece | Hungary | Ireland | Kazakhstan | Latvia | Liechtenstein | Lithuania | Luxembourg | Malta | Mexico | Moldova | Netherlands | Norway | Portugal | Romania | Saudi Arabia | Serbia | Singapore | Slovakia | Slovenia | South Africa | Sweden | Tunisia | Ukraine | United Arab Emirates

Jeremias high quality products to be installed only by selected experts.

