

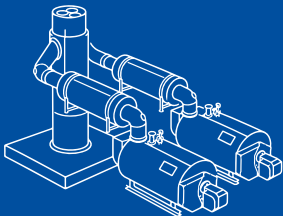

EXHAUST SILENCERS

Sound engineering solutions for exhaust systems



GLOBAL EXPERTISE IN EXHAUST AND NOISE CONTROL TECHNOLOGY

The **Jeremias Group**, headquartered in Wassertrüdingen, is your leading global partner for exhaust solutions in industry and power generation. As a family-run business with over **50 years of experience** and **1,400 employees**, we stand for quality 'Made by Jeremias'.

With production sites in Germany, Spain, Poland, the UK, the USA, France, the Czech Republic and Denmark, as well as **over 1,500 silencer projects completed worldwide**, we offer global expertise to meet every requirement.



OUR PORTFOLIO

We are your **one-stop supplier** for industrial exhaust systems – from the smallest accessory to a tailor-made solution:

- **CHIMNEY SYSTEMS:** High-quality modular and steel chimneys
- **FLUE GAS DUCTS:** Robust connection solutions from the boiler/engine outlet to the chimney
- **EXHAUST DAMPERS:** as control, energy saving or bypass dampers
- **EXHAUST SILENCERS:** Perfectly tailored to engines, boilers, biomass and special applications

YOUR BENEFITS

- **VERSATILITY:** Extensive standard range as well as customised configurations
- **CERTIFIED QUALITY:** Performance guarantee through factory acceptance testing on our inhouse test bench
- **FULL SERVICE:** Professional on-site noise measurements and individual advice
- **EVERYTHING FROM A SINGLE PROVIDER:** Silencers and complete exhaust systems perfectly matched to each other

Benefit from engineering and project experience that sets new standards – from your **one-stop supplier for the most sophisticated system solutions!**



PRECISION IS OUR TRADEMARK

Using **state-of-the-art design tools and CFD simulations**, we guarantee silencer solutions that are precisely tailored to your requirements.

- **Tailored design:** Compact construction and minimised costs.
- **Precise simulation:** Precise calculation of pipe acoustics, flow noise and shell radiation.
- **Guaranteed performance:** Validation of results on our own test benches and through on-site noise measurements.



There is a wide range of different silencer types and series available. Nevertheless, selecting the right exhaust silencer for the specific application is not rocket science.



Our experts provide fast, competent, and solution-oriented advice.

JEREMIAS SILENCER HOTLINE:



+49 9832 68 68 8001



schalldaempfer@jeremias.de

BOILER

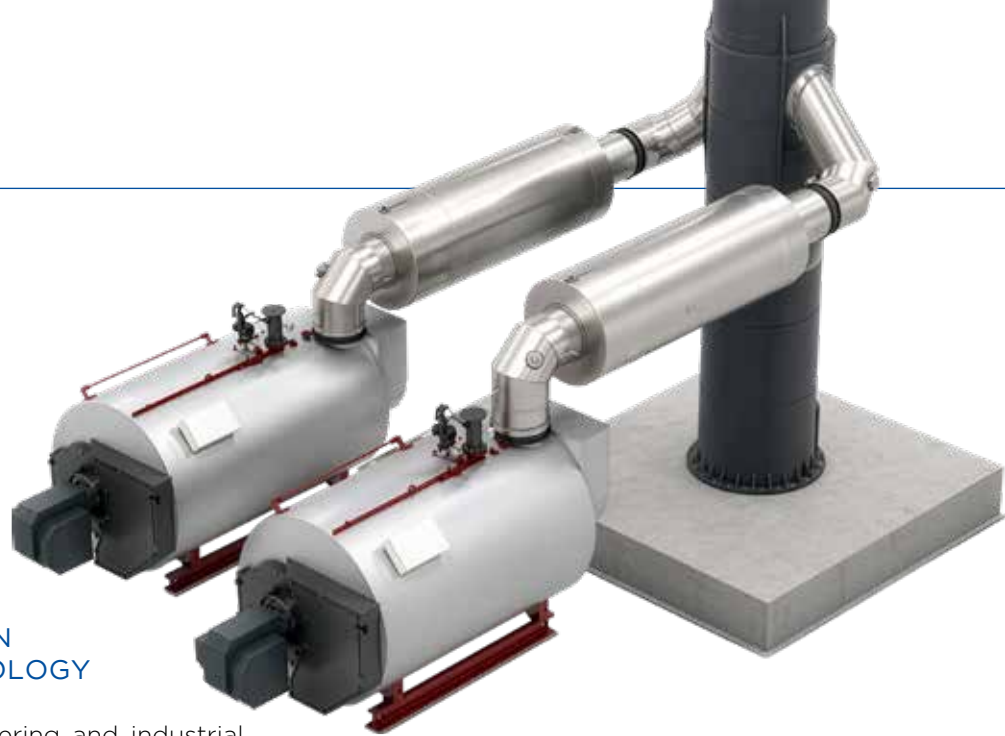

EFFICIENT SOUND INSULATION FOR MODERN BOILER TECHNOLOGY

In modern building services engineering and industrial energy supply, boilers are at the heart of heat generation. However, where maximum performance is required, operational noise is inevitable: the exhaust gases released during combustion not only carry heat but also transmit unwanted sound waves through the flue system into the surrounding environment.

THE CHALLENGE: A COMPLEX NOISE SPECTRUM

The noise spectrum of a boiler is highly complex. It consists primarily of two components:

- **Burner-specific, from the flame and combustion:** Direct emissions from the boiler room, often containing low-frequency components.
- **Fan noise:** A characteristic “whirring” sound of the installed forced-draft burners often results in high exhaust noise levels with broadband superposition.
- **Flow noise:** Turbulent pressure fluctuations of the hot exhaust gas are generated within the boiler.

The resulting complex sound profile poses a particular challenge for sound insulation.

PRECISE SOLUTIONS FOR EVERY TYPE OF BOILER

Whether in the food industry, district heating networks, or process steam generation: The requirements for noise emissions vary depending on the type of system and performance class:

- 1. Fire-tube & large-water-tube boilers:** With outputs of up to **30 MW**, robust designs ensure stable steam and hot water quality for industrial processes and energy supply.
- 2. Hot water boilers:** Often combined with economisers (heat exchangers) in industrial and building heating systems, these highly efficient systems require equally efficient acoustic optimisation.
- 3. Steam boilers:** A steam boiler converts water into gaseous process steam under extreme pressure and intense heat, which releases enormous thermodynamic forces and consequently leads to noise generation.





JEREMIAS: TECHNOLOGY FOR MAXIMUM SILENCE

To meet these challenges, Jeremias offers a comprehensive range of exhaust silencers. Whilst medium- and high-frequency sounds are usually reduced by conventional **absorption silencers**, broadband emissions (particularly from forced-draft burners) require the use of **resonance or combined silencers**.

Our systems are specifically designed to differ in terms of damping technology, construction and degree of damping, in order to guarantee the optimal acoustic solution for systems of all sizes.

FREQUENCY SPECTRUMS OF THE DIFFERENT SILENCER TYPES

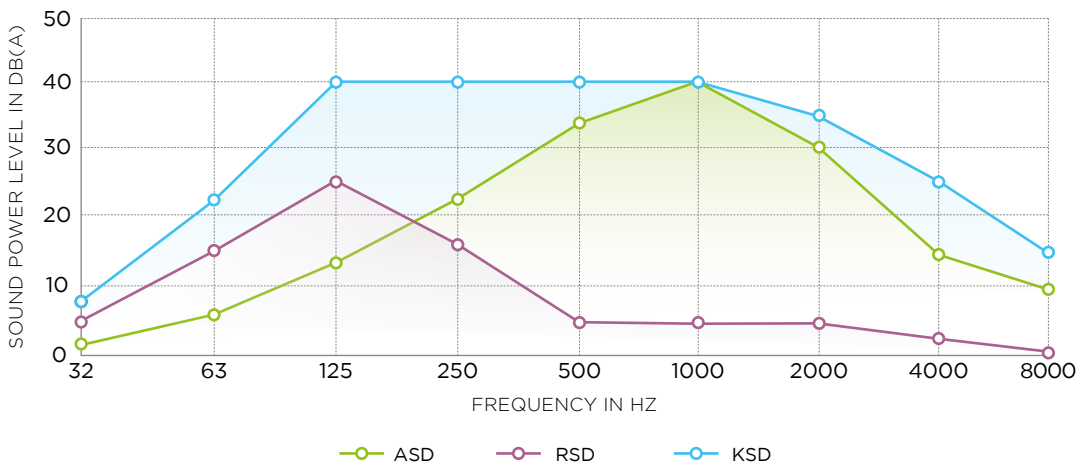

- ASD** — Absorption silencer
- RSD** — Resonance silencer
- KSD** — Combined silencer

EFFECTIVE NOISE REDUCTION
The right solution for every requirement

ROBUST & DURABLE
Designed for continuous industrial use

CUSTOMISED
Individual configuration for your system

CERTIFIED QUALITY
to international standards

EMISSION REDUCTION BY SILENCER TYPE (15 MW FORCE-DRAFT BOILER)

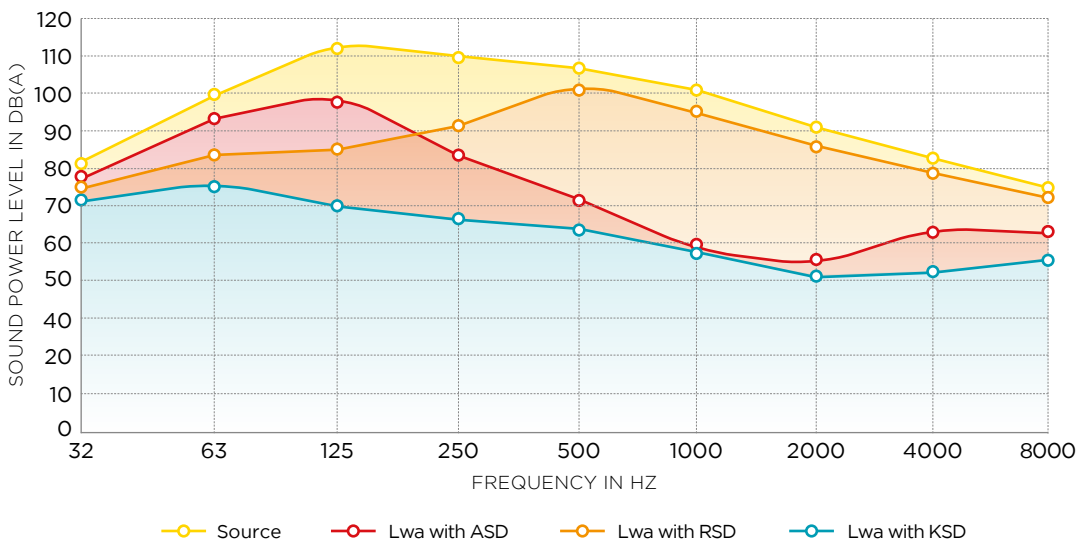

- Source** — Raw emissions
- Lwa with ASD** — Absorption silencer
- Lwa with RSD** — Resonance silencer
- Lwa with KSD** — Combination silencer

TYPES OF SILENCERS FOR BOILERS:

ABSORPTION SILENCER: ATTENUATION OF MID AND HIGH FREQUENCIES

Silencers operating on the absorption principle achieve sound reduction primarily in the mid and high frequency range from 250 Hz onwards through the use of open-pored, sound-absorbing material, e.g. mineral wool. Through an internal perforated plate, the sound waves from the exhaust gas flow enter the mineral wool behind it, where they are absorbed and the sound energy is converted into heat due to friction effects.

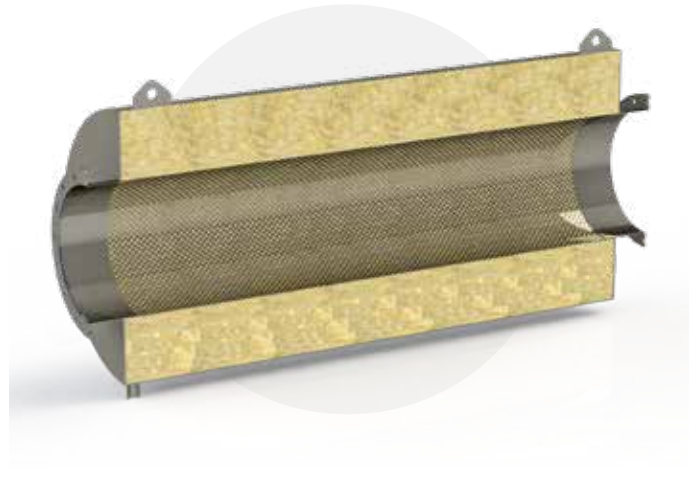

RESONANCE SILENCERS: DAMPING IN THE LOW-FREQUENCY RANGE

Resonance silencers are ideal for low frequencies with little exhaust back pressure. The sound is directed through perforated plates into hollow chambers, where it is minimised by antiphase interference. By arranging multiple chambers, the damping characteristics can be individually tuned to different frequency ranges. As the chambers are located outside the exhaust gas flow, flow resistance remains little: Excellent for systems with moderate pressure conditions.



COMBINED SILENCER: BROADBAND-TUNED DAMPING

If broadband noise reduction is required, the resonance and absorption principles can also be combined into one single silencer. In the first section of the silencer, noise is damped by being directed from the exhaust pipe through a perforated plate into the outer hollow chambers, where it is reduced. In the second section, the classic absorption zone provides additional reduction of mid- and high-frequency sounds.

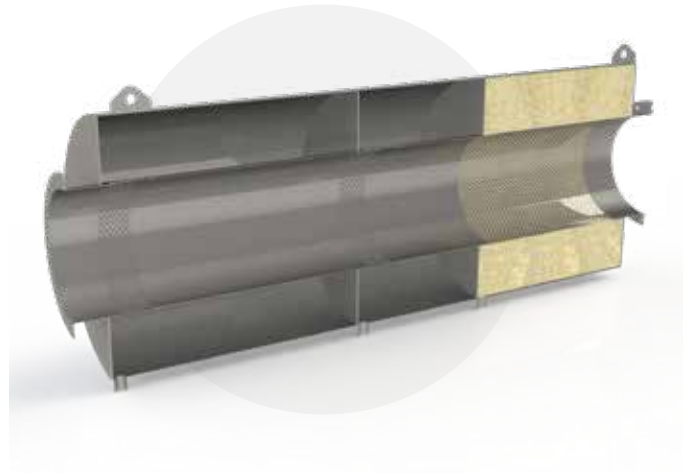

All of the silencer types mentioned are also suitable for vertical installation of the chimney!



SPECIAL TYPE: SOUND-ABSORBING CORE

Designed as an absorption silencer, the sound-absorbing core is an ideal solution for simple retrofitting, as it is installed directly into the chimney outlet without requiring any major modifications to the existing flue system. Thanks to its aerodynamic design, the integrity of the system is maintained. To ensure the long-term safe and accurate operation of the flue gas system despite the slightly increased flow resistance, a supplementary cross-sectional calculation taking into account the additional flow resistance of the sound-absorbing core is required.

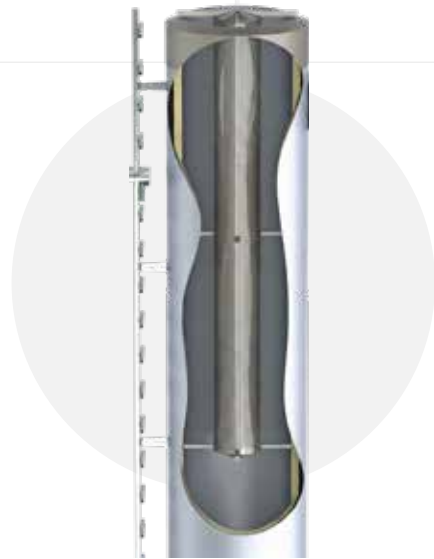

SPECIAL TYPE: SILENCER WITH INTERNAL SOUND-ABSORBING CORE

For maximum efficiency, the sound-absorbing core can also be integrated as a component within a silencer. This allows the damping performance to be significantly increased further, particularly from the mid-frequency range onwards, whilst maintaining the same space. Even though the sound-absorbing core installed in the centre of the 'main silencer' has a cylindrical design and is optimised for flow, the higher flow resistance on the exhaust side must be taken into account.

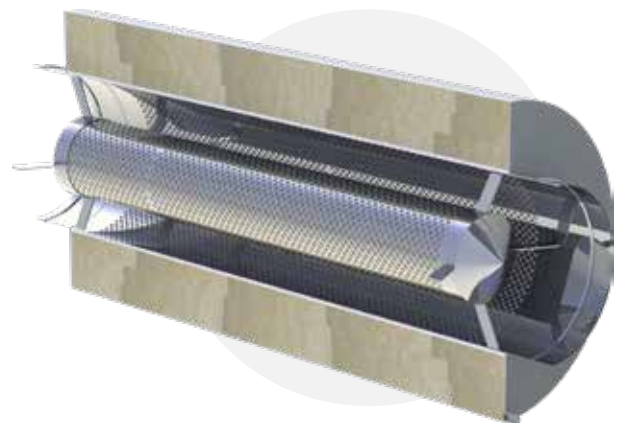

SPECIAL TYPE: SPLITTER SILENCERS

For large cross-sections, exhaust/pipe/splitter silencers are a high-performance alternative for industrial use. They consist of parallel baffles (splitters) filled with mineral absorption material. Inlet and outlet flow profiles reduce exhaust back pressure. This design allows for high broadband noise attenuation and precise tuning to the specific frequency spectrum.



CASE STUDY

MODERNISATION OF A EXHAUST SILENCING SYSTEM FOR A BOILER PLANT IN BERLIN



PROJECT OVERVIEW

As part of the modernisation of a large central heating plant in Berlin, the exhaust system for four natural-gas-fired hot water generators (**total output approx. 173 MW**) had to be replaced. As the plant serves to provide peak and part-load supply, intermittent operation (frequent start-ups and shutdowns) leads to low exhaust gas temperatures with a corresponding build-up of condensate water. This had to be taken into account, as well as the high noise insulation requirements of the urban environment.

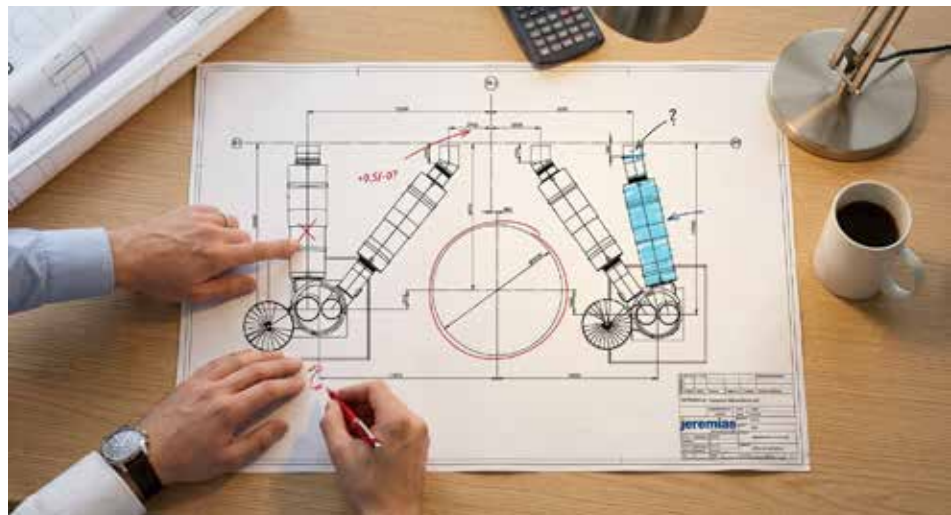

PROJECT SCOPE AND EXECUTION

Jeremias delivered a turnkey exhaust gas system that was precisely tailored to the demanding operating conditions of the plant and the limited space constraints in the urban area:



- **FSA DOUBLE-FLUE STEEL CHIMNEYS:** Construction of two free-standing, 37-metre-high steel chimneys with a diameter of approx. 3 m. Each chimney was designed as a double-flue system to discharge the exhaust gases from the four boilers separately and efficiently.



- **CONDENSATE MANAGEMENT:** Design and installation of four flue gas ducts (one per boiler) in a consistently moisture-resistant design to permanently prevent corrosion under low-load conditions.



- **NOISE PROTECTION IN RESIDENTIAL AREAS:** Acoustic design and integration of four high-performance silencers, taking into account measured noise levels and existing silencers. A particular feature here was the millimetre-precise integration of existing structures in the largest (56 MW) generator.



PROJECT DETAILS

	LOCATION	Berlin
	APPLICATION	Industrial boiler plant
	SYSTEM	FSA-2 / Exhaust silencer
	MATERIAL	Stainless steel (1.4301 / 1.4571)
	TYPE	Custom design
	NOISE REDUCTION	25 dB low frequency <100 Hz



OUTCOME

Thanks to the new, highly durable system solution, operational reliability was significantly increased. The successfully completed BlmSch measurement confirmed the precise design of the system.

At the same time, the optimized sound insulation ensures whisper-quiet operation: a fundamental requirement for power plants in densely populated metropolitan areas.

CASE STUDY

SOUND INSULATION SOLUTION FOR A LARGE-SCALE BOILER PLANT IN DORTMUND

PROJECT OVERVIEW

As part of a challenging industrial project in Dortmund, a customised exhaust gas technology solution was implemented that combines maximum performance within a very confined space.

The core of the plant consists of two gas-fired forced-draft boilers, each with an **output of 11 MW**, including modern economisers. Due to the high performance characteristics, precise noise management was required in order to reliably comply with a maximum sound power level of **LWA 75 dB(A)** at the chimney outlet.

An **FSA-2 type** chimney system with two separate DN 800 internal flues was installed for exhaust gas discharge. The main technical challenge was the effective attenuation of low frequencies **below 100 Hz**, a range in which conventional standard solutions are not sufficiently effective.

Jeremias developed special high-performance combination silencers made of corrosion-resistant stainless steel with a sound attenuation of up to 35 dB. The fully insulated silencers feature eight tuned frequency chambers, a flow-optimized inner core and statically relevant connection flanges for direct load-bearing.

Due to the extremely limited installation space, an external placement of the silencers was not possible. Therefore, the components were designed with an extremely slender geometry, measuring 8.5 m in length and only 1.3 m in outer diameter, and were directly integrated into the vertical internal flues of the chimney system.

PROJECT SCOPE AND EXECUTION



- **CUSTOM PLANNING**

High-performance combination silencers for large-scale industrial boiler plants.

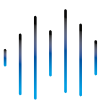

- **LOW-FREQUENCY ACOUSTIC DAMPING**

Effective noise reduction of critical frequencies below 100 Hz.

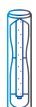

- **COMPACT DESIGN**

Direct integration into the vertical internal flues of the chimney system.









- **SPACE OPTIMISATION**

Maximum space saving in the boiler house thanks to a slim design.





PROJECT DETAILS

	LOCATION	Dortmund
	APPLICATION	Large-scale boiler plant
	SYSTEM	FSA-2 / Combined silencer
	MATERIAL	Stainless steel (1.4571)
	TYPE	Custom design
	NOISE REDUCTION	Up to 35 dB



OUTCOME

Reliable compliance with a sound power level of LWA 75 dB(A) despite high plant performance and critical low-frequency noise components.

The compact integration of the silencers enabled maximum space savings while maintaining high acoustic efficiency.

CASE STUDY

STEEL CHIMNEY, EXHAUST GAS SILENCING SYSTEM, AND FLUE GAS DUCT FOR A NEW BOILER HOUSE IN FREIBURG



PROJECT OVERVIEW

For an industrial site near Freiburg im Breisgau, a customised solution for flue gas routing and noise attenuation was implemented for two natural gas-fired steam boilers, each with a capacity of **50 t/h**.

The challenge was to safely discharge a flue gas volume of around **44,000 Nm³/h** per boiler at an operating temperature of 125 °C, whilst complying with strict noise protection requirements. The project was implemented using a freestanding double-flue steel chimney of type FSA-2. This design allowed the flue gas streams of both boilers to be combined in a space-saving manner while fully maintaining the thermal independence of the individual internal flues. The acoustic centerpiece of the system consists of two combined exhaust gas silencers of type KSD-F40. The combination of resonator and absorptive silencer technology, supplemented by an additional acoustic insulation core, provides broadband noise attenuation of approximately 40 dB. As a result, a precisely defined sound power level of **LWA = 82 dB(A)** was achieved at the chimney outlet.

The silencers were designed for operating temperatures of **up to 300 °C** and ensure maximum operational reliability even under demanding industrial conditions.

PROJECT SCOPE AND EXECUTION

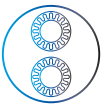

- **DOUBLE-FLUE STEEL CHIMNEY FSA-2**

Freestanding double-flue steel chimney for space-saving discharge of both exhaust gas streams.



- **BROADBAND SOUND DAMPING**

KSD-F40 combined silencer with resonator and absorber technology for approx. 40 dB noise reduction.

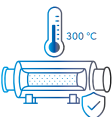

- **HIGH OPERATING TEMPERATURE**

Designed for temperatures up to 300 °C to ensure maximum operational safety.









- **ROBUST CONSTRUCTION MADE OF STAINLESS STEEL**

Corrosion-resistant stainless steel construction made from material grade 1.4571 for long-term low-emission operation.



PROJECT DETAILS

	LOCATION	Freiburg
	APPLICATION	Industrial steam boiler plant
	SYSTEM	FSA-2 / KSD-F40
	MATERIAL	Stainless steel (1.4301)
	TYPE	Custom design
	NOISE REDUCTION	approx. 40 dB

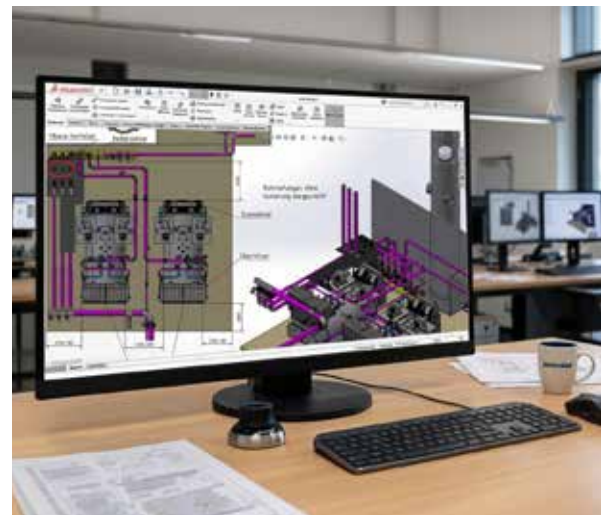

OUTCOME

The intelligent exhaust gas system ensures the safe and efficient handling of large flue gas volumes while delivering outstanding acoustic performance.

The combination of space-saving chimney technology and high-performance broadband silencing provides a long-term solution for low-emission, reliable plant operation.

CASE STUDY

CUSTOMISED EXHAUST AND NOISE PROTECTION SOLUTION FOR DISTRICT HEATING PLANT IN AUSTRIA



PROJECT OVERVIEW

In Mellach, a strategically important hub for Austria's energy supply, Jeremias as a full-service provider implemented a customised flue gas system for three high-performance hot water boilers, each with an output of **33 MW**.

The project comprised the design, manufacturing and installation of a central industrial chimney system, including the complete flue gas ducting and dedicated acoustic solutions to meet the strictest noise emission limits. Particular attention was paid to the acoustic design of the silencers. Through **high-quality internal insulation** and targeted tuning to **critical resonance ranges**, highly efficient noise reduction was achieved under demanding operating conditions.

In addition to this, Jeremias developed the necessary steel structures to safely support the silencers and ensure the professional installation of all components within the overall system. Beyond commissioning, a long-term service agreement was concluded with the operator for **annual maintenance** to ensure the highest safety and quality standards over the long run.

PROJECT SCOPE AND EXECUTION



- **STEEL CHIMNEY**

Manufacturing and installation of the central industrial chimney as the key component of the system.

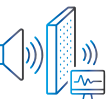

- **FLUE GAS SYSTEM**

Engineering and delivery of the complete flue gas piping system for three hot water boilers.



- **ACOUSTIC ENGINEERING**

Integration of specially tailored silencers to meet the strictest noise control requirements.



- **STEEL CONSTRUCTION**

Engineering of the necessary steel structures to ensure safe load support for the silencers.









- **SERVICE & MAINTENANCE**

Long-term operational reliability through annual maintenance under a service contract.



PROJECT DETAILS

	LOCATION	Mellach, Austria
	APPLICATION	District heating plant
	SYSTEM	FSA-3 / Combined silencer
	MATERIAL	Stainless steel (1.4301 / 1.4571)
	TYPE	Custom design
	NOISE REDUCTION	45 dB



OUTCOME

The new flue gas system ensures a safe and efficient flue gas routing whilst delivering high acoustic performance.

By combining tailor-made sound insulation technology, robust steel construction and a long-term maintenance concept, a permanently reliable and safe system solution has successfully been implemented.

GERMANY

Jeremias Abgastechnik GmbH
Opfenrieder Str. 12
D-91717 Wassertrüdingen
Phone: +49 9832 6868-50
Mail: welcome@jeremias-group.com
www.jeremias.de

POLAND

www.jeremias.pl

USA

www.jeremiasinc.com

SPAIN

www.jeremias.es

CROATIA

www.jeremias.hr

ITALY

www.jeremias.it

CZECH REPUBLIC

www.jeremias.cz

FINLAND

www.jeremias.fi

FRANCE

www.jeremias.fr

UNITED KINGDOM

www.jeremias.uk

JEREMIAS IS REPRESENTED IN THE FOLLOWING COUNTRIES:

Austria | Switzerland | Belarus | Belgium | Brazil | Bulgaria | China (Hongkong) | Denmark | Estonia | Greece | Hungary | Ireland | Kazakhstan | Latvia | Liechtenstein | Lithuania | Luxembourg | Malta | Mexico | Moldova | Netherlands | Norway | Portugal | Romania | Saudi Arabia | Serbia | Singapore | Slovakia | Slovenia | South Africa | Sweden | Tunisia | Ukraine | United Arab Emirates

Jeremias high quality products to be installed only by selected experts.

